

MALE-FEMALE STRAIGHT METER GAS BALL VALVE WITH LEVER HANDLE

Produced in accordance with Standards EN-331 & UNE-60718

CE marking in accordance with EU legislation

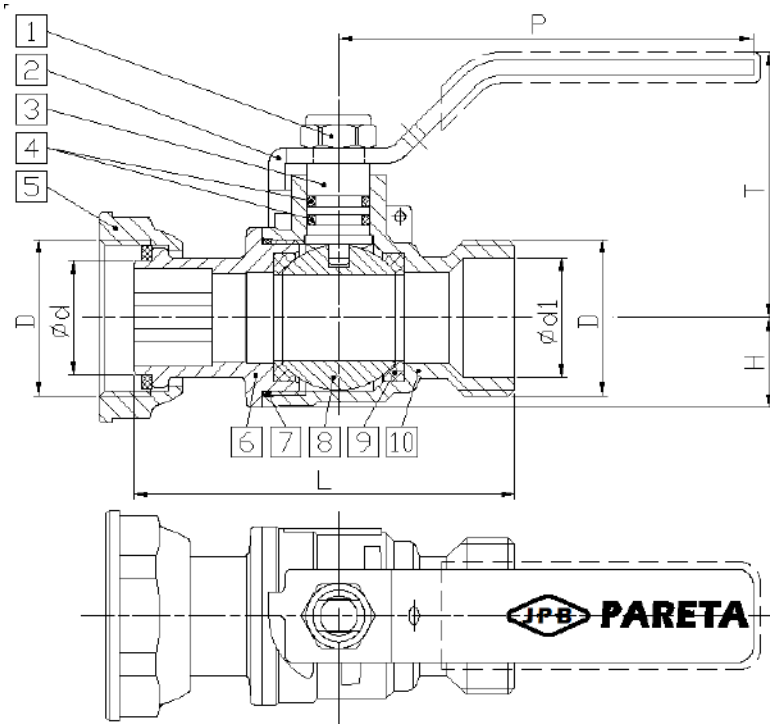

Nº	COMPONENT	MATERIAL
1	Self-lock nut	Zinc plated steel
2	Lever handle	Dacromet steel
3	Shaft	Brass
4	Shaft O-Rings	NBR
5	Rotating Free Nut	Brass
6	Bonnet	Brass
7	Bonnet O-Ring	NBR
8	Ball	Brass
9	Teflon seat	P.T.F.E.
10	Valve Body	Brass

CÓDIGO	DN	O.T.	D	Ød	Ød1	L	H	T	P	BOX	EAN
7810170200	15	≤7 Nxmm	3/4"	19,0±0,2	19,5±0,2	71±2,0	15±1	39,5	70	48	8435085502460
7810170300	20	≤7 Nxmm	7/8"	22,0±0,2	23,0±0,2	74±2,0	17±1	51,5	80	36	8435085500244
7810170400	25	≤7 Nxmm	1"1/4	31,0±0,2	31,5±0,2	100±2,0	28±1	57,0	112	20	8435085500251
7810170600	40	≤14 Nxmm	2"	46,0±0,2	46,5±0,2	140±2,0	35±1	71,0	151	5	8435085500268

MATERIALS

- The brass material used is in accordance with Standards EN 12165, EN 12164 or EN 1982
- The rubber gaskets used and o-rings are in accordance with Standard EN 549
- The lubricants used are in accordance with Standard EN 377

TECHNICAL FEATURES

- Valves suitable for gases of 1st, 2nd & 3rd family.
- Maximum operating temperature: +60° C.
- Minimum operating temperature : - 40° C.
- Operating torque: see column in upper table (O.T.).
- Maximum operating pressure : 5 Bar
- These valves have no specific flow direction, so their installation position is indistinct.

OPERATION

- To close the flow, turn the handle clockwise. Once closed, the handle must be perpendicular to the flow direction.
- To open the flow, turn the handle anticlockwise. Once opened, the handle must be parallel to the flow direction. For the models with automatic safety lock system, push on the handle to release the safety lock and turn it anticlockwise (push & turn).
- To ensure the correct valve operation, it is absolutely necessary that the valve does not remain NEVER in intermediate positions of opening or closing under any reason.
- It is recommend realising opening and closing movements of the valve, along its 90 degrees of turn, once a month at least.



DATA SHEET



MALE-FEMALE STRAIGHT METER GAS BALL VALVE WITH LEVER HANDLE

Produced in accordance with Standards EN-331 & UNE-60718

CE marking in accordance with EU legislation

HANDLE LOCK SYSTEM

- 1 Turn the handle clockwise and ensure that the valve is in CLOSED position
- 2 Unscrew the nut or screw that holds the handle until it is completely free of the shaft.
- 3 Remove the handle from the valve.
- 4 Turn the handle 180 degrees.
- 5 Assemble the handle on the valve again, ensuring that the turning stop of the handle is inserted into the locking groove of the body neck.
- 6 Assemble the nut or screw and screw it in until the end ensuring that the handle is locked.

For the models with automatic safety lock system, the locking device is in the handle. However, the blocking procedure is the same as detailed above.

PERIODIC TESTS

- Maintenance operations are not required. It is only recommended realising opening and closing movements of the valve, along its 90 degrees of turn, once a month at least as described in the OPERATION section.
- During the life of the valve, leaking tests required by the current regulations must be carried out.
- Periodically check that the valve has a proper operation, mainly the opening and closing movements along its 90 degrees of turn.
- Also periodically check the general appearing of the valve, ensuring that there are not any damaged part.

CAUTIONS

- Any deterioration or breakage of the valve or part of it requires complete replacement of the same one.
- Deterioration of any part of the valve means non-compliance of with the requirements of the Standards.
- Ensure that the valve is the suitable for the device or network to which we install and allows the flow required for the intended use.
- All the installation must be done in accordance with the existing code of good practice, local laws and approved national regulations.
- To check lacking of leaks in the installation, NEVER USE flames or any substance or product that is flammable or susceptible to fire or explosion.
- Do not use this valve for any other purpose than that one that the valve has been designed and manufactured, under any circumstance.

INSTALLATION

- Check that pipes of the installation in which the valve is to be installed are free of gas or any flammable product or substance, as well as any other product which can damage the vital parts of the sealing elements. It is mandatory to clean installation's pipes prior to the valve installation, guaranteeing the absence of strange elements which could damage the closing and sealing system of the valve.
- Assemble the valve to network device or pipe using always suitable sealing elements and fittings for each type of valve. These fittings must carry out with regulations' and standards' specifications required by the current regulations.
In case the fittings used require welding operations, DO NOT make such operations with the fitting connected to the valve, an excess of temperature could damage its vital parts of the sealing system. Also, be sure to remove all the fitting's parts that are rubber or liable to be damage in the welding process.
- Always assemble the valve to its connection ends designed for this purpose. DO NOT do it for the body, neck or handle.
- Check that connections are free of tensions, whether traction, compression, torque, bending or shearing.
- NEVER hit any part of the valve under any circumstances.
- DO NOT alter or modify any part of the valve or its components.
- Once the installation is finished, it is mandatory to carry out leaking tests required by the current regulations. These tests must always be prior to putting on service of the device or network.